

**REACH**  
PNLX-CC Series  
Série PNLXX-CC



ICES-005  
NMB-005

T24  
JA8  
CERTIFIED  
CERTIFIÉ

IC  
RATED  
HOMOLOGUÉ

WET LOCATION  
EMPLACEMENT MOUILLÉ

COASTAL FRIENDLY  
RÉSISTANT À L'AIR SALIN

AIR TIGHT  
ÉTANCHE À L'AIR



Works with most dimmers. Refer to DALS website for dimmer compatibility list.  
Fonctionne avec la plupart des gradateurs.  
Voir le site web DALS pour la liste de gradateurs compatibles.

**ITEMS INCLUDED IN THE BOX**  
ARTICLES INCLUS DANS LA BOÎTE

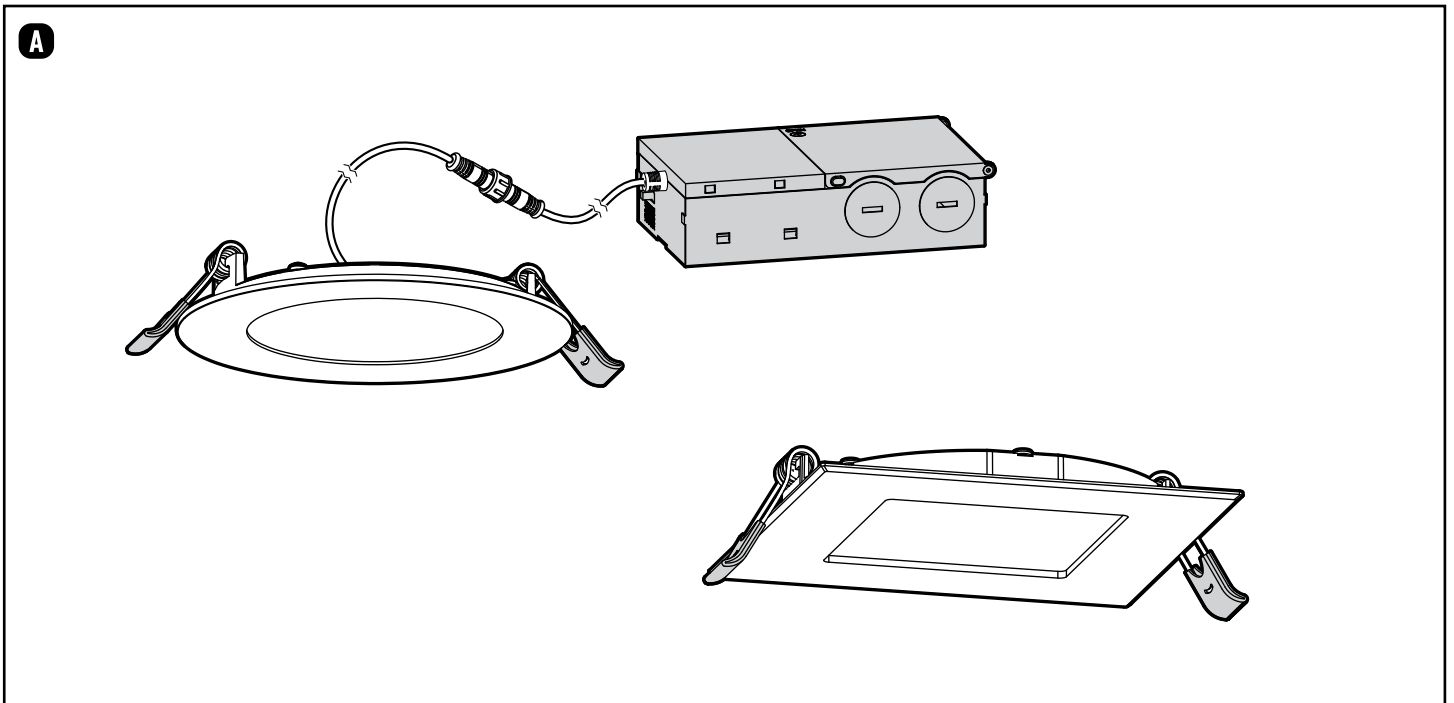

**SIDE VIEW OF INSTALLATION**  
VUE DE CÔTÉ DE L'INSTALLATION D'ÉCLAIRAGE

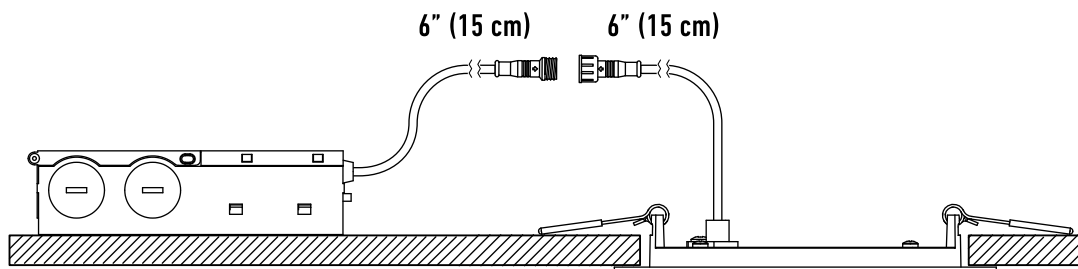

**WARRANTY:**

DALS offers a 5 year warranty from the date of purchase which covers repairs or replacements of defective parts of the housing, optics, and electronics.

**GARANTIE:**

DALS offre une garantie de 5 ans à partir de la date d'achat qui couvre la réparation ou le remplacement des pièces du boîtier, des pièces optiques et électroniques défectueuses.



**CUSTOMER SERVICE:**  
1 877 430-1818  
info@dals.com

**SERVICE À LA CLIENTÈLE:**  
1 877 430-1818  
info@dals.com

**⚡ BEFORE STARTING INSTALLATION, SHUT THE LINE FEED POWER OFF USING THE CIRCUIT BREAKER.**

Instructions pertaining to a risk of fire, electric shock or injury to persons. Installation must be done according to local electrical codes. Installation must be done by a qualified electrician.

**AVANT DE DÉBUTER L'INSTALLATION, COUPER L'ALIMENTATION DU FIL DU SECTEUR À L'AIDE DU DISJONCTEUR.**

Ces instructions se rapportent à un risque d'incendie, de chocs électriques ou de blessures corporelles. L'installation doit être effectuée conformément aux codes électriques locaux. L'installation devrait être effectuée par un électricien qualifié.

**1 Drill hole in ceiling and prepare supply wires. Install and unshield the line feed wire 6" (15 cm) and strip wires 5/8" (1.6 cm). Bring supply power to junction box through knockout.**

Percer le trou dans le plafond et préparer les fils d'alimentation. Installer et dénuder le fil du secteur de 6" (15 cm) et dénuder les fils de 5/8" (1,6cm). Apporter l'alimentation électrique jusque dans la boîte de jonction.

**PNL3-CC:**

Ø3-3/8"

**PNL4-CC:**

Ø4-1/4"

**PNL4SQ-CC:**

Ø4-1/2"

4-1/2" x 4-1/2"

**PNL6-CC:**

Ø6-3/8"

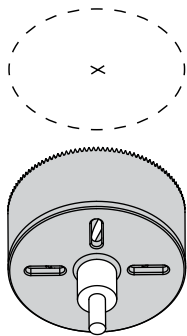

**2 Open the lid of the junction box. Use the supplied connectors and follow the connection details. Once the connection is complete, close the junction box.**

Ouvrir le couvercle de la boîte de jonction. Utiliser les connecteurs fournis et suivre les détails de connexion. Une fois la connexion terminée, refermer la boîte de jonction.

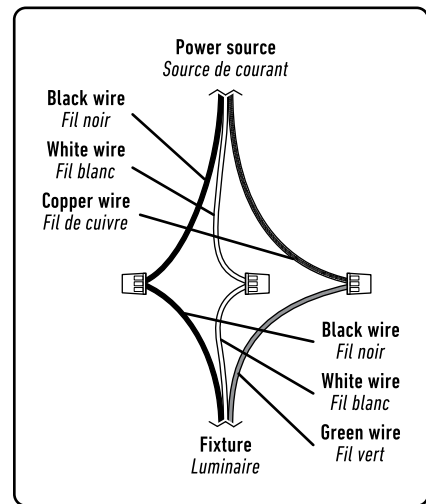

**3 Select the color temperature and insert the junction box through the cut-out of the ceiling.**

Sélectionner la température de couleur et insérer la boîte de jonction dans le plafond.

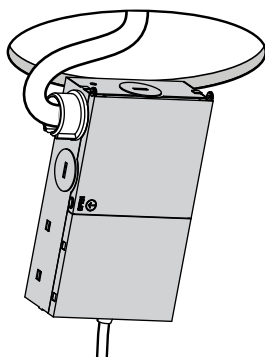

**4 Compress the springs and push the fixture in the opening. It is easier to do one spring at a time.**

Comprimer les ressorts et pousser l'appareil dans le trou. Il est préférable d'y aller un ressort à la fois.

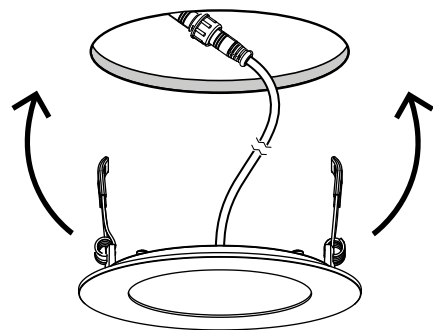

**FCC STATEMENT**

- This device complies with Part 15 of the FCC Rules. Operation is subject to the following two conditions:
  - (1) This device may not cause harmful interference, and
  - (2) This device must accept any interference received, including interference that may cause undesired operation.
- Changes or modifications not expressly approved by the party responsible for compliance could void the user's authority to operate the equipment.

This equipment has been tested and found to comply with the limits for a Class B digital device, pursuant to part 15 of the FCC Rules. These limits are designed to provide reasonable protection against harmful interference in a residential installation. This equipment generates, uses and can radiate radio frequency energy and, if not installed and used in accordance with the instructions, may cause harmful interference to radio communications. However, there is no guarantee that interference will not occur in a particular installation. If this equipment does cause harmful interference to radio or television reception, which can be determined by turning the equipment off and on, the user is encouraged to try to correct the interference by one or more of the following measures:

- Reorient or relocate the receiving antenna.
- Increase the separation between the equipment and receiver.
- Connect the equipment into an outlet on a circuit different from that to which the receiver is connected.
- Consult the dealer or an experienced radio/TV technician for help.

**ISED NOTICE**

- This device contains licence-exempt transmitter(s)/receiver(s) that comply with Innovation, Science and Economic Development Canada's licence-exempt RSS(s). Operation is subject to the following two conditions:
  - (1) This device may not cause interference.
  - (2) This device must accept any interference, including interference that may cause undesired operation of the device.

- Changes or modifications not expressly approved by the party responsible for compliance could void the user's authority to operate the equipment.

**AVIS ISED**

- Cet appareil contient des émetteurs / récepteurs exemptés de licence conformes aux RSS (RSS) d'Innovation, Sciences et Développement économique Canada. Le fonctionnement est soumis aux deux conditions suivantes :

- (1) Cet appareil ne doit pas causer d'interférences.
  - (2) Cet appareil doit accepter toutes les interférences, y compris celles susceptibles de provoquer un fonctionnement indésirable de l'appareil.
- Cet appareil numérique ne dépasse pas les Règlements sur l'interférence radio par un appareil numérique de classe B stipulés dans les Règlements sur l'Interférence radio d'industrie Canada.