



DALS LIGHTING

Canada
80, de la Seigneurie Blvd., E.
Blainville, Quebec J7C 4N1

U.S.A.
4383, NW 124th Ave.,
Coral Springs, Florida 33065

877.430.1818
info@dals.com
dals.com

MODEL DSWC05-CC

NAME Shield

5" Dark Sky Wall Sconce

These 5" and 7" dark-sky friendly wall fixtures offer focused, energy-efficient illumination while minimizing light pollution, making them ideal for environmentally conscious outdoor spaces.

PROJECT _____ **TYPE** _____

DATE _____ **QTY** _____

NOTES

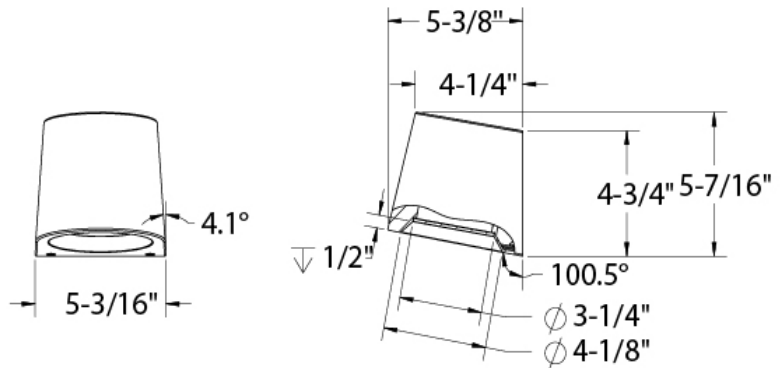

LIGHT DISTRIBUTION

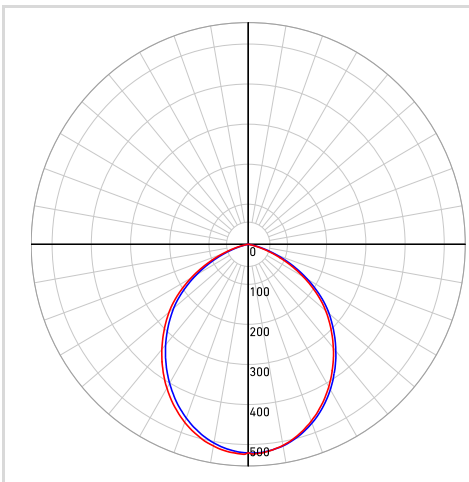

*Lumen output measured at 3000k

QUICK SPECS

Size	5"
Watts (W)	16
Delivered lumens*	1200
CRI	90
Voltage (v)	120v
Beam angle (deg)	100
Mounting	Screwed in
Lifespan (hrs)	50 000
Binning	5 SDCM
LED model	SMD 2835
Light direction	Down
Color temperature	2200,2700K,3000K,3500K,4000K

ELECTRICAL DETAILS

Environment	Wet
Location	Outdoor
Operating temp. (° C)	-40 to 40
IP rating	IP54
Input voltage (V)	120
Output voltage (V)	40
Output current (mA)	400
Power factor	98
Driver type	Constant current
THD	≤ 20%
Certifications	ETL, FCC, ICES

ORDERING GUIDE

DSWC05-CC - _____
Finish
BK - Black ●

CONSTRUCTION

Lens material	Glass
Lens type	Frosted
Finish type	Powder painting
Housing material	Aluminum

WHAT'S IN THE BOX	ACCESSORIES	ADAPTORS
LED wall sconce Mounting bracket Mounting hardware Wire nuts Instruction sheet		

RECOMMENDED DIMMER LIST*

BRAND	MODEL	DIMMER SPECS	GRADE	MIN	MAX	MAX LOAD
Dals	SM-DIMSW Smart Dimmer*	Triac, 250W LED/CFL	Compatible	5	100	15
Lutron	DVCL-153PR-WH-C*	Triac, 150 W Dimmable CFL/LED	Compatible	6	100	9
Lutron	CTCL-153PDH-WH-C*	Triac, 150 W Dimmable CFL/LED	Compatible	6	100	9
Lutron	STCL-153PH-WH-C*	Triac, 150 W Dimmable CFL/LED	Compatible	1	100	9
Lutron	MACL-153MRHW-WHC*	Triac, 150 W Dimmable CFL/LED	Compatible	0	100	9
Lutron	DVELV-300P-WH	ELV 300W	Compatible	6	86	18
Lutron	MA-PRO-WH*	ELV, 250W LED/CFL	Compatible	0	100	15
Lutron	Caseta PD-6WCL-WH-R-C*	Triac, 300W Dimmable CFL/LED	Compatible	0	99	9
Lutron	Caseta PD-5NE-WH-C*	ELV, LED—up to 250 W	Compatible	2	100	15
Lutron	Caseta PD-10NXD-WH*	Triac, LED—up to 250 W	Compatible	0	100	15
Leviton	DSM10-1LZ*	Triac, 450W Dimmable CFL/LED	Compatible	2	100	27
Leviton	6674*	Triac, 150 W Dimmable CFL/LED	Compatible	8	100	9
Leviton	PL06-10Z*	Triac, 150 W Dimmable CFL/LED	Compatible	7	100	9
Leviton	DSL06-1LZ*	Triac, 150 W Dimmable CFL/LED	Compatible	6	100	9
Leviton	D26HD-742-1RW*	Triac, 300W LED/CFL	Compatible	8	100	18
Legrand	RHCL453PNICCV4*	Triac, 450W Dimmable CFL/LED	Compatible	10	100	27
Legrand	ADTP703TUM4*	Triac, 450W Dimmable CFL/LED	Compatible	0	100	27
Legrand	ADPD453LM2*	Triac, 450W Dimmable CFL/LED	Compatible	10	100	27
Legrand	RHL373PW*	Triac, 250W LED	Compatible	0	0	15
Control 4	C4-APD120-WH	ELV, 120W LED	Compatible	0	100	7
Control 4	C4-FPD120-WH	Triac, 200W LED	Compatible	0	100	12
Commercial Electric	HPDA311CWB*	Triac, 150W LED & CFL	Compatible	0	0	9
TP-Link	HS220*	Triac, 150 W, Dimmable LED (MLV)	Compatible	3	100	9

*With Low-End Adjustment Feature

Minimal buzzing noise may occur with some dimmers

WARRANTY

DALS offers a 5-year warranty from the date of purchase which covers repairs or replacement of defective parts of the housing, optics, and electronics. To contact DALS customer service call 1-877-430-1818 or send an e-mail to info@dals.com.