



DALS LIGHTING

Canada
80, de la Seigneurie blvd., E.
Blainville, Quebec j7c 4n1

U.S.A.
4383, NW 124th Ave.,
Coral Springs, Florida 33065

877.430.1818
info@dals.com
dals.com

MODEL 2003

NAME Access

4 Inch Round Regressed Down Light

Our new LED Panel lights are more accessible than ever before. The sleek and minimal construction allows for the easiest of installations.

PROJECT

TYPE

DATE

QTY

NOTES

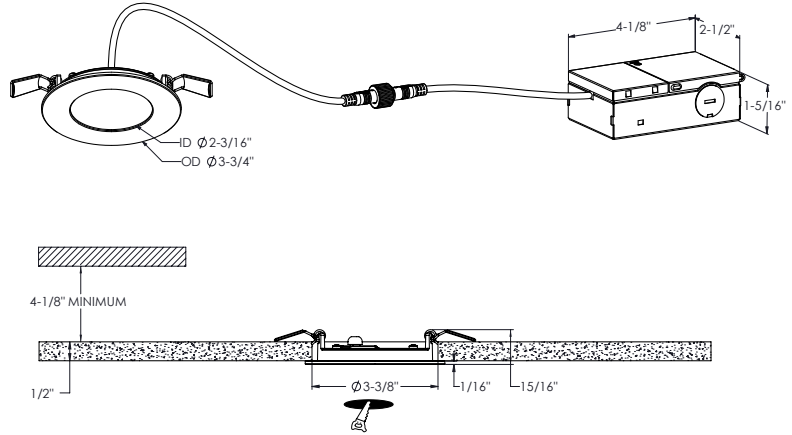

LIGHT DISTRIBUTION

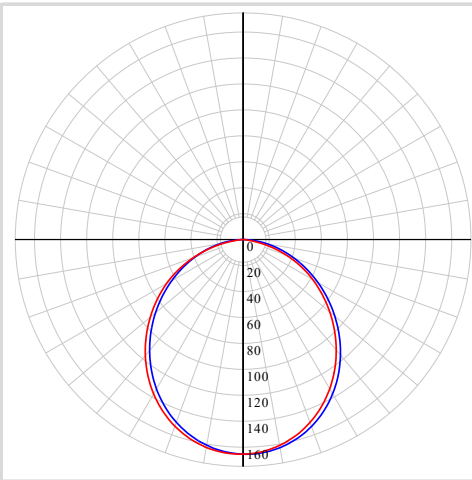

QUICK SPECS

Size	3"
Watts (W)	6
Delivered lumens*	400
CRI	80
Voltage (v)	120
Beam angle (deg)	110°
Cut hole size (in)	3-3/8"
Lifespan (hrs)	35,000hrs
FT rating	FT1
Binning	7 SDCM
LED model	SMD 2835
Color temperature	3000k

ELECTRICAL DETAILS

Environment	Damp
Location	Interior
Operating temp. (° C)	-20 to 40
IP rating	IP44
Input voltage (V)	120
Output voltage (V)	33-37
Output current (mA)	155
Power factor	70
Driver type	Constant current
THD	< 20%
Certifications	ETL, FCC, ICES, ES
	IC, ASTM E283-04

*Lumen output measured at 3000k

ORDERING GUIDE

2003	-		-	
		Voltage		Finish
		BLANK - 120v Triac dimming		WH - White
		V - 120-277-347V 0-10v dimming		

CONSTRUCTION

Lens	Frosted
Optic type	Flat lens
Lens material	Plastic
Finish type	Matte
Housing material	Aluminum

WHAT'S IN THE BOX	ACCESSORIES	ADAPTORS
<ul style="list-style-type: none"> LED recessed fixture Junction box 3x Push-in wire connectors Mounting hardware Instruction sheet 	<ul style="list-style-type: none"> RFP-UNI Universal drilling plate RFP-23 Drilling plate 	<ul style="list-style-type: none"> 2000-EXT8FT 96" extension cord for recessed fixtures 2000-EXT20FT 240" extension cord for recessed fixtures

RECOMMENDED DIMMER LIST*

BRAND	MODEL	DIMMER SPECS	GRADE	MIN	MAX	MAX LOAD
Dals	SM-DIMSW Smart Dimmer*	Triac, 250W LED/CFL	Compatible	9	100	42
Lutron	DVCL-153PR-WH-C*	Triac, 150 W Dimmable CFL/LED	Compatible	9	100	25
Lutron	CTCL-153PDH-WH-C*	Triac, 150 W Dimmable CFL/LED	Compatible	2	100	25
Lutron	STCL-153PH-WH-C*	Triac, 150 W Dimmable CFL/LED	Compatible	10	100	25
Lutron	DVELV-300P-WH	300W electronic low voltage dimmer	Compatible	1	98	50
Lutron	MA-PRO-WH*	ELV, 250W LED/CFL	Compatible	0	100	42
Lutron	Caseta PD-6WCL-WH-R-C*	Triac, 300W Dimmable CFL/LED	Compatible	4	100	50
Lutron	Caseta PD-5NE-WH-C*	ELV, LED—up to 250 W	Compatible	0	100	42
Lutron	Caseta PD-10NXD-WH*	Triac, LED—up to 250 W	Compatible	3	98	42
Leviton	DSM10-1LZ*	Triac, 450W Dimmable CFL/LED	Compatible	11	99	75
Leviton	6674*	Triac, 150 W Dimmable CFL/LED	Compatible	8	100	25
Leviton	D26HD-742-1RW*	Triac, 300W LED/CFL	Compatible	9	100	50
Legrand	RHCL453PNICCV4*	Triac, 450W Dimmable CFL/LED	Compatible	10	100	75
Legrand	ADTP703TUM4*	Triac, 450W Dimmable CFL/LED	Compatible	1	100	75
Legrand	RHL373PW*	Triac, 250W LED	Compatible	0	94	42
Control 4	C4-APD120-WH	ELV, 120W LED	Compatible	0	100	20
Control 4	C4-FPD120-WH	Triac, 200W LED	Compatible	0	99	33
Commercial Electric	HPDA311CWB*	Triac, 150W LED & CFL	Compatible	2	100	25
TP-Link	HS220*	Triac, 150 W, Dimmable LED (MLV)	Compatible		99	25

WARRANTY

DALS offers a 5-year warranty from the date of purchase which covers repairs or replacement of defective parts of the housing, optics, and electronics. To contact DALS customer service call 1-877-430-1818 or send an e-mail to info@dals.com.