



DALS LIGHTING

Canada
80, de la Seigneurie blvd., E.
Blainville, Quebec j7C 4N1

U.S.A.
4383, NW 124th Ave.,
Coral Springs, Florida 33065

877.430.1818
info@dals.com
dals.com

MODEL RGR1-CC

NAME RGR

1in Round Regressed Downlight

When choosing a recessed fixture, eliminating glare is a priority. The unique positioning of the LED module in this series of downlights will meet that important need.

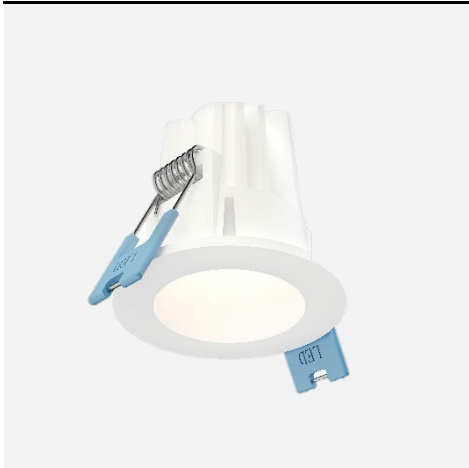

PROJECT _____ **TYPE** _____

DATE _____ **QTY** _____

NOTES

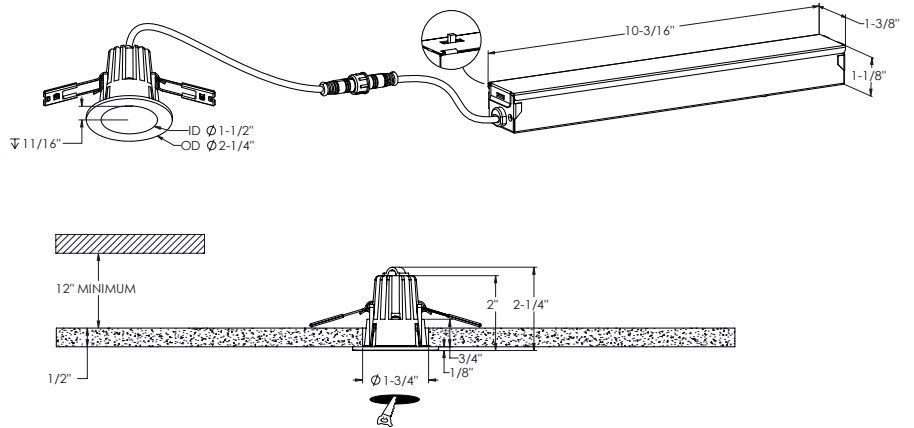

LIGHT DISTRIBUTION

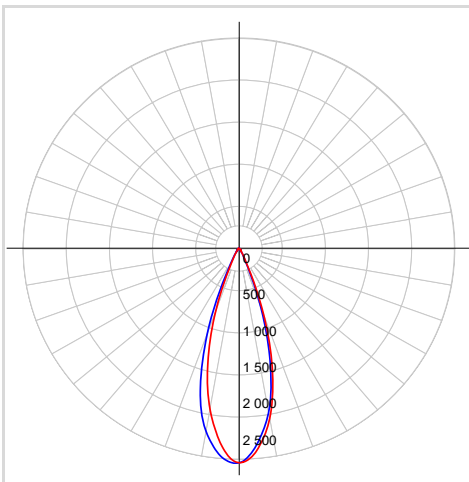

*Lumen output measured at 3000k

QUICK SPECS

Size	1"
Watts (W)	6
Delivered lumens*	450
CRI	90
Voltage (v)	120
Beam angle (deg)	40
Cut hole size (in)	1-3/4"
Lifespan (hrs)	50000
FT rating	FT6
Binning	3 SDCM
LED model	COB
Color temperature	2700K/3000K/3500K/4000K/5000K

ELECTRICAL DETAILS

Environment	Wet
Location	Indoor/Outdoor
Operating temp. (° C)	-20 to 40
IP rating	IP44
Input voltage (V)	120
Output voltage (V)	32-48
Output current (mA)	141
Power factor (%)	90
Driver type	Constant current
THD	≤ 30%
Certifications	ETL, FCC, ICES, JA8/T24
	IC, ASTM E283-04

ORDERING GUIDE

RGR1-CC	-	_____	-	_____
		Voltage		Finish
		BLANK - 120v Triac dimming		WH - White ○ BK - Black ●

CONSTRUCTION

Lens material	Acrylic
Optic type	Optical lens
Finish type	Matte
Housing material	Aluminum

WHAT'S IN THE BOX

LED recessed fixture
 Junction box
 3x Push-in wire connectors
 Mounting hardware
 Instruction sheet

ACCESSORIES

[RFP-01](#)
 Drilling plate

ADAPTORS

[REC-CC-EXT8FT](#)
 96" extension cord for recessed fixtures

[REC-CC-EXT20FT](#)
 240" extension cord for recessed fixtures

RECOMMENDED DIMMER LIST*

BRAND	MODEL	DIMMER SPECS	GRADE	MIN	MAX	MAX LOAD
Lutron	DVELV-300P-WH	300W electronic low voltage dimmer	Compatible	6	97	50
Lutron	MA-PRO-WH	ELV, 250W LED/CFL	Compatible	0	98	42
Lutron	Caseta PD-5NE-WH-C	ELV, LED—up to 250 W	Compatible	2	99	42
Control 4	C4-APD120-WH	ELV, 120W LED	Compatible	1	100	20
tp-link	HS220*	Triac, 150 W, Dimmable LED (MLV)	Compatible	0	100	25

*With Low-End Adjustment Feature

Minimal buzzing noise may occur with some dimmers

WARRANTY

DALS offers a 5-year warranty from the date of purchase which covers repairs or replacement of defective parts of the housing, optics, and electronics. To contact DAL'S customer service call 1-877-430-1818 or send an e-mail to info@dals.com.